

OFFICIAL PLAT

WATERMARK 7TH ADDITION

CITY OF LINO LAKES
COUNTY OF ANOKA
SEC. 12 & 13, TWP. 31, RGE. 22

KNOW ALL PERSONS BY THESE PRESENTS: That U.S. Home, LLC, a Delaware limited liability company, owner of the following described property:

Outlot C, Outlot D and Outlot F, WATERMARK 5TH ADDITION, Anoka County, Minnesota
and
Outlot A, WATERMARK 6TH ADDITION, Anoka County, Minnesota

Has caused the same to be surveyed and platted as WATERMARK 7TH ADDITION and does hereby dedicate to the public for public use the public ways and the drainage and utility easements as shown on this plat.

In witness whereof said U.S. Home, LLC, a Delaware limited liability company, has caused these presents to be signed by its proper officer this 23rd day of April, 2024.

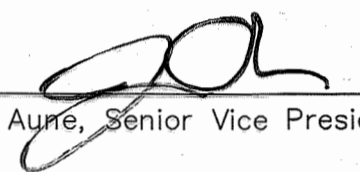
U.S. HOME, LLC

Jon Aune, Senior Vice President

STATE OF MINNESOTA
COUNTY OF HENNEPIN

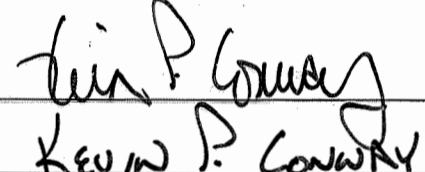
This instrument was acknowledged before me on this 23rd day of APRIL, 2024 by Jon Aune, Senior Vice President of U.S. Home, LLC, a Delaware limited liability company, on behalf of the company.

 (Signed)
Kevin P. Conway (Printed)
Notary Public, HENNEPIN COUNTY, MINNESOTA
My commission expires JANUARY 31, 2028

I Thomas R. Balluff do hereby certify that this plat was prepared by me or under my direct supervision; that I am a duly Licensed Land Surveyor in the State of Minnesota; that this plat is a correct representation of the boundary survey; that all mathematical data and labels are correctly designated on this plat; that all monuments depicted on this plat have been, or will be correctly set within one year; that all water boundaries and wet lands, as defined in Minnesota Statutes, Section 505.01, Subd. 3, as of the date of this certificate are shown and labeled on this plat; and all public ways are shown and labeled on this plat.

Dated this 12th day of APRIL, 2024.

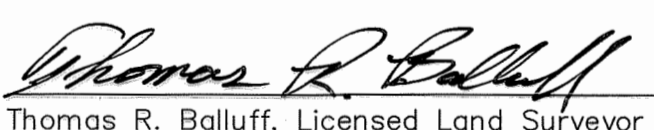
Thomas R. Balluff, Licensed Land Surveyor
Minnesota License No. 40361

STATE OF Minnesota
COUNTY OF Anoka

This instrument was acknowledged before me on this 12th day of April, 2024 by Thomas R. Balluff.

 (Signed)
Cynthia J. Morical (Printed)
Notary Public, Hennepin County, Minnesota
My commission expires January 31, 2025

CITY COUNCIL, CITY OF LINO LAKES, MINNESOTA

This plat of WATERMARK 7TH ADDITION was approved and accepted by the City Council of the City of Lino Lakes, Minnesota at a regular meeting thereof held this 8th day of April, 2024, and said plat is in compliance with the provisions of Minnesota Statutes, Section 505.03, Subd. 2.

CITY COUNCIL, CITY OF LINO LAKES, MINNESOTA

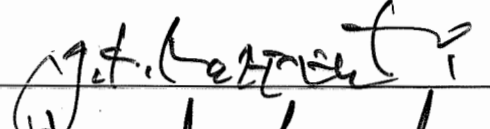
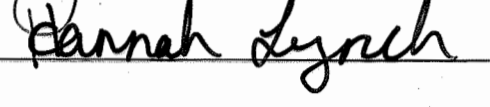
By:  Mayor
By:  Clerk

COUNTY SURVEYOR

I hereby certify that in accordance with Minnesota Statutes, Section 505.021, Subd. 11, this plat has been reviewed and approved this 15th day of October, 2024.

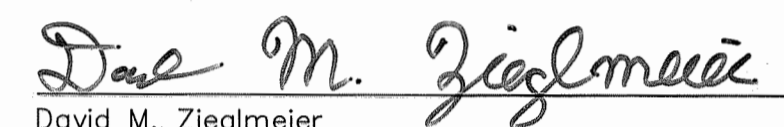
David M. Ziegler
Anoka County Surveyor

COUNTY AUDITOR/TREASURER

Pursuant to Minnesota Statutes, Section 505.021, Subd. 9, taxes payable in the year 2024 on the land hereinbefore described have been paid. Also, pursuant to Minnesota Statutes, Section 272.12, there are no delinquent taxes and transfer entered this 15th day of October, 2024.

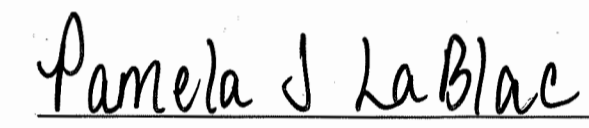
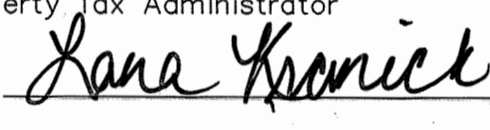
Pamela J. LaBlac
Property Tax Administrator
By:  Deputy

COUNTY RECORDER/REGISTRAR OF TITLES

County of Anoka, State of Minnesota

I hereby certify that this plat of WATERMARK 7TH ADDITION was filed in the office of the County Recorder/Registrar of Titles for public record on this 18th day of October, 2024, at 11:43 o'clock A.M. and was duly recorded as Document Number 2423381.002.

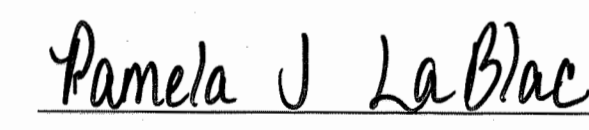
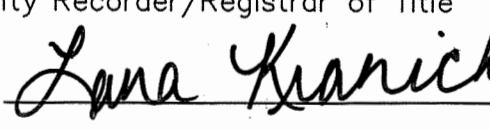
Pamela J. LaBlac
County Recorder/Registrar of Title
By:  Deputy

WATERMARK 7TH ADDITION

INTERSTATE HIGHWAY 35E

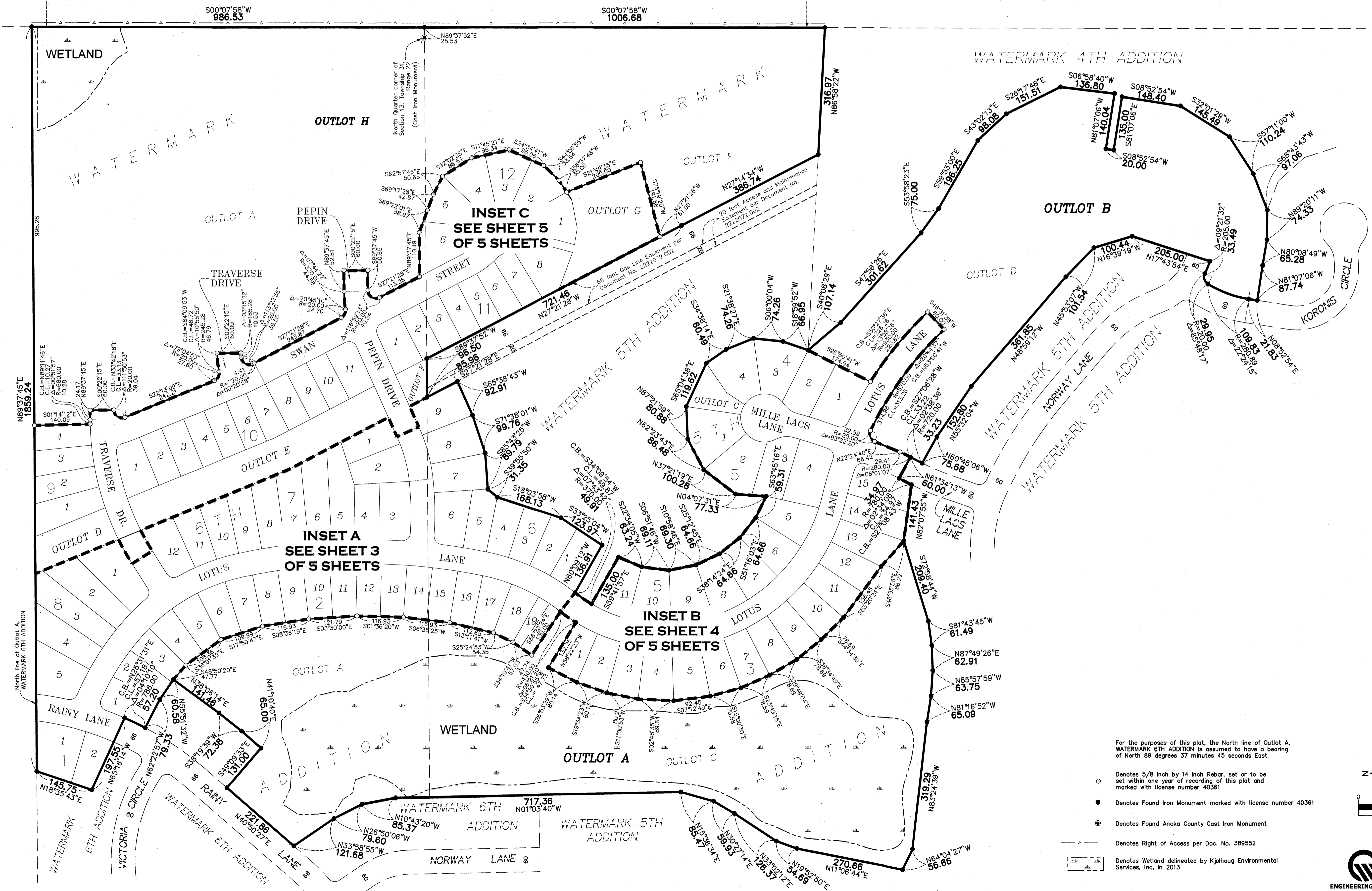

For the purposes of this plat, the North line of Outlot A, WATERMARK 6TH ADDITION is assumed to have a bearing of North 89 degrees 37 minutes 45 seconds East.

- Denotes 5/8 inch by 14 inch Rebar, set or to be set within one year of recording of this plat and marked with license number 40361
- Denotes Found Iron Monument marked with license number 40361
- ⊙ Denotes Found Anoka County Cast Iron Monument
- △ Denotes Right of Access per Doc. No. 389552
- W Denotes Wetland delineated by Kjalhaug Environmental Services, Inc. in 2013

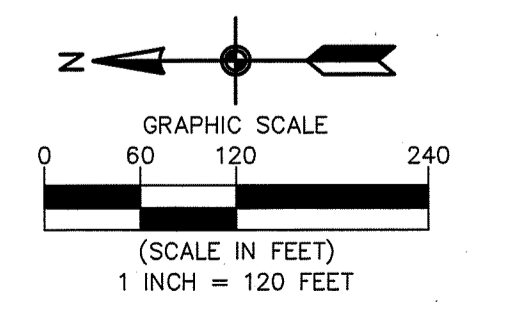

WATERMARK 7TH ADDITION

INSET A

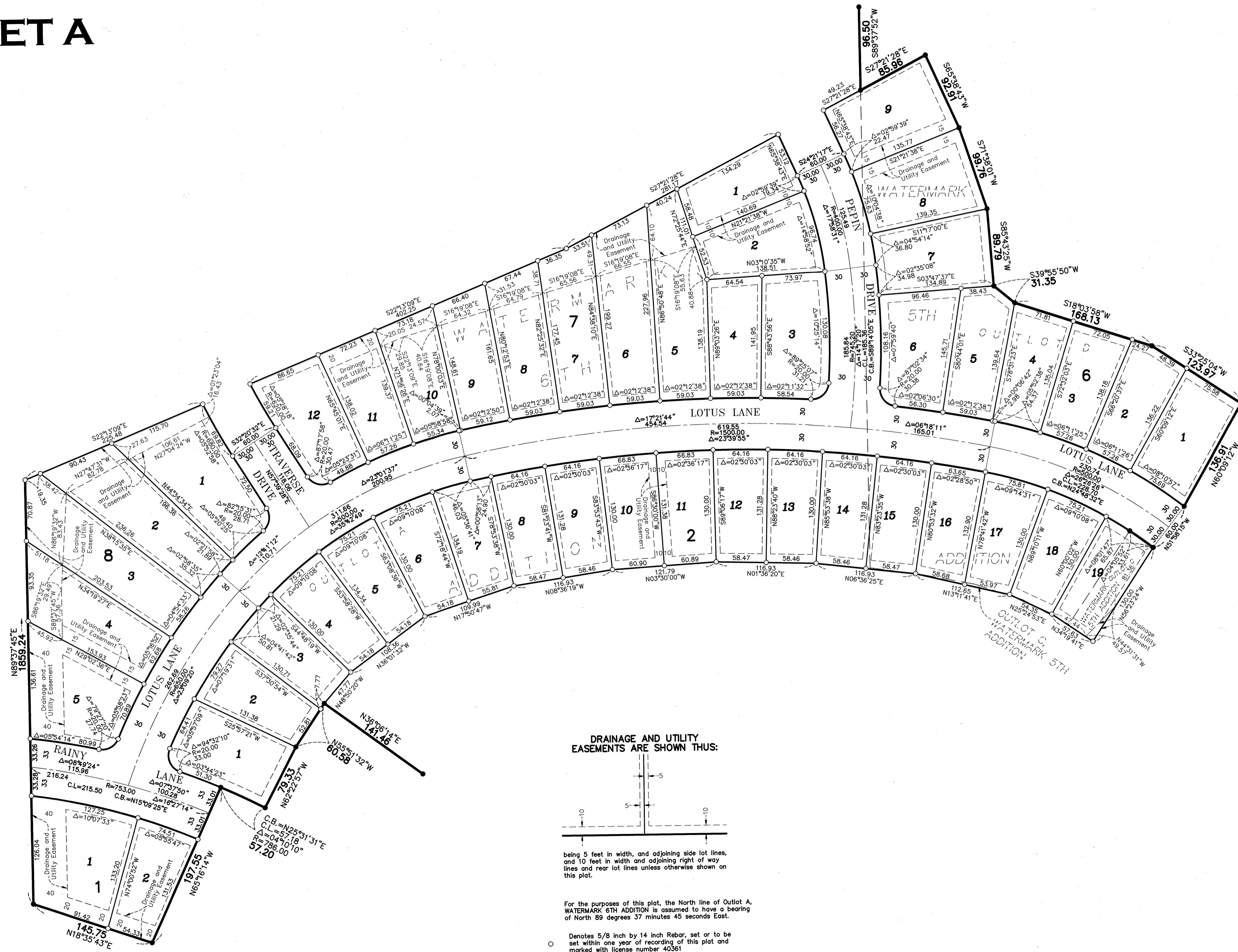

DRAINAGE AND UTILITY EASEMENTS ARE SHOWN THUS:

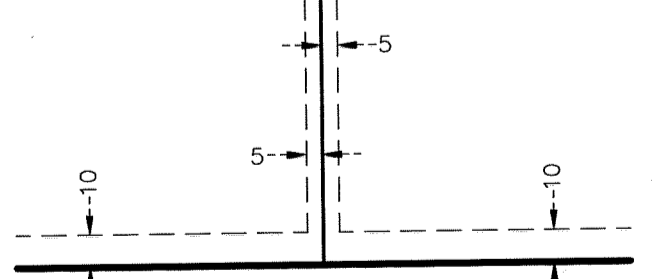

being 5 feet in width, and adjoining side lot lines, and 10 feet in width and adjoining right of way lines and rear lot lines unless otherwise shown on this plat.

For the purposes of this plat, the North line of Outlot A, WATERMARK 6TH ADDITION is assumed to have a bearing of North 89 degrees 37 minutes 45 seconds East.

○ Denotes 5/8 inch by 14 inch Rebar, set or to be set within one year of recording of this plat and marked with license number 40361

● Denotes Found Iron Monument marked with license number 40361

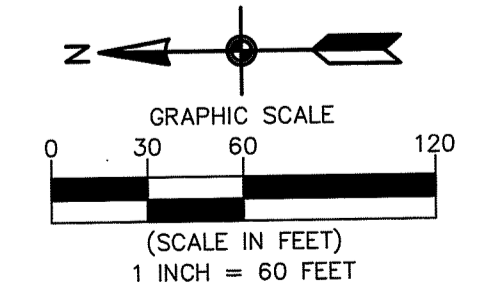

CARLSON MCCAIN
ENGINEERING \ SURVEYING \ ENVIRONMENTAL

WATERMARK 7TH ADDITION

INSET B

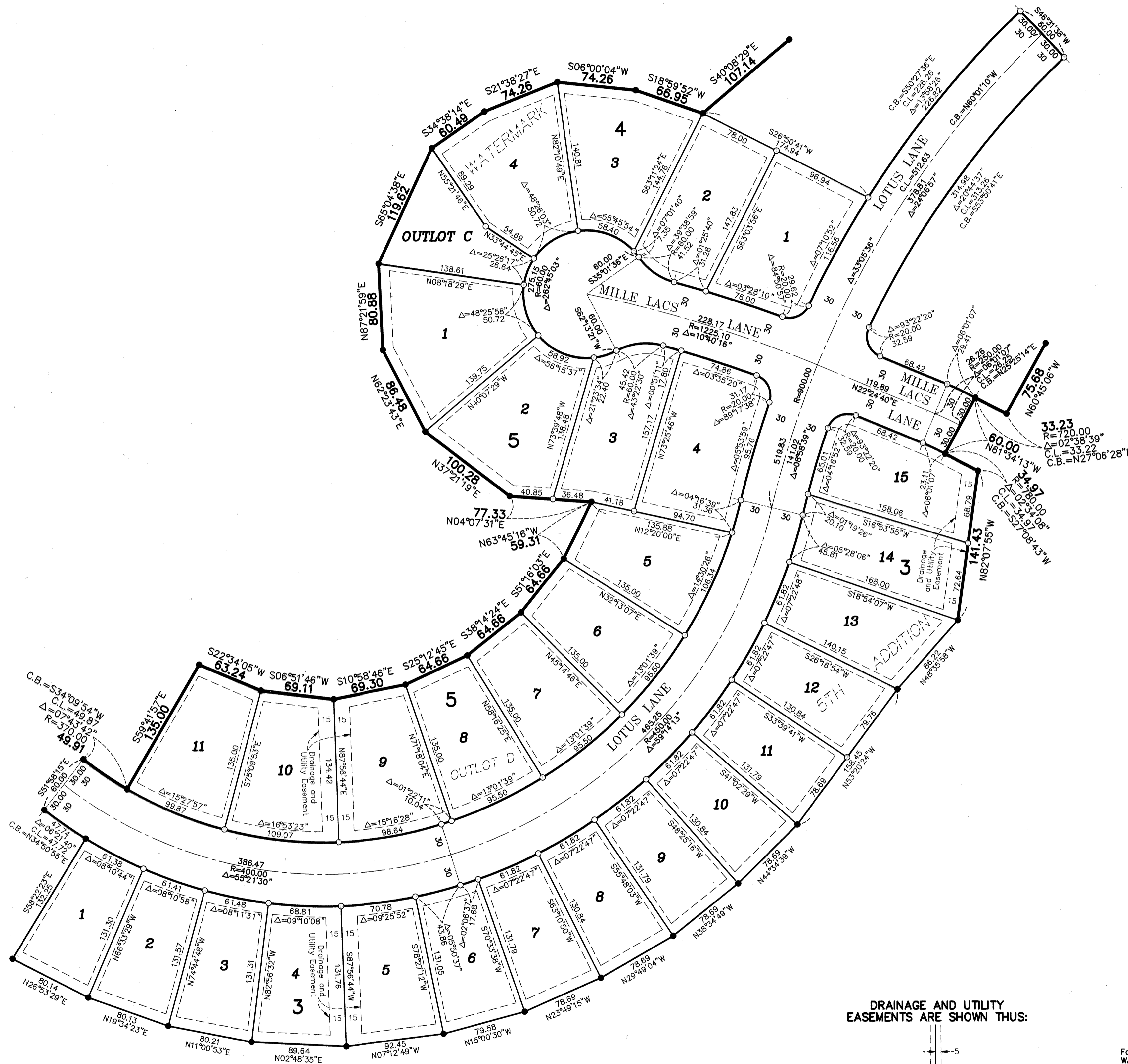

Drainage and Utility Easements are shown thus:

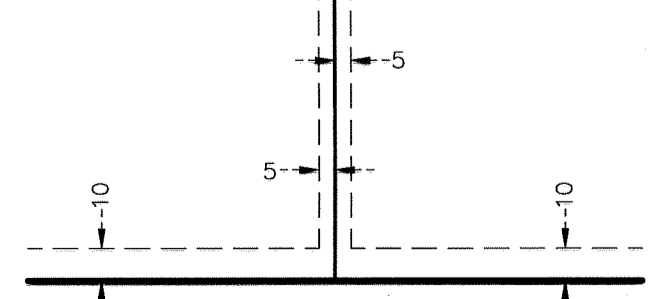

being 5 feet in width, and adjoining side lot lines, and 10 feet in width and adjoining right of way lines and rear lot lines unless otherwise shown on this plat.

For the purposes of this plat, the North line of Outlot A, Watermark 6th Addition is assumed to have a bearing of North 89 degrees 37 minutes 45 seconds East.

- Denotes 5/8 inch by 14 inch Rebar, set or to be set within one year of recording of this plat and marked with license number 40361
- Denotes Found Iron Monument marked with license number 40361

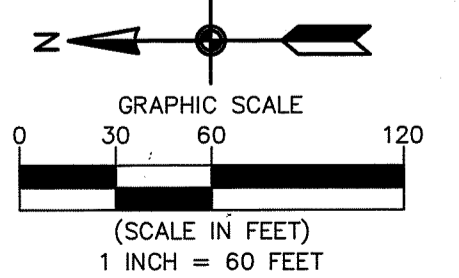

WATERMARK 7TH ADDITION

CITY OF LINO LAKES
COUNTY OF ANOKA
SEC. 12 & 13, TWP. 31, RGE. 22

INSET C

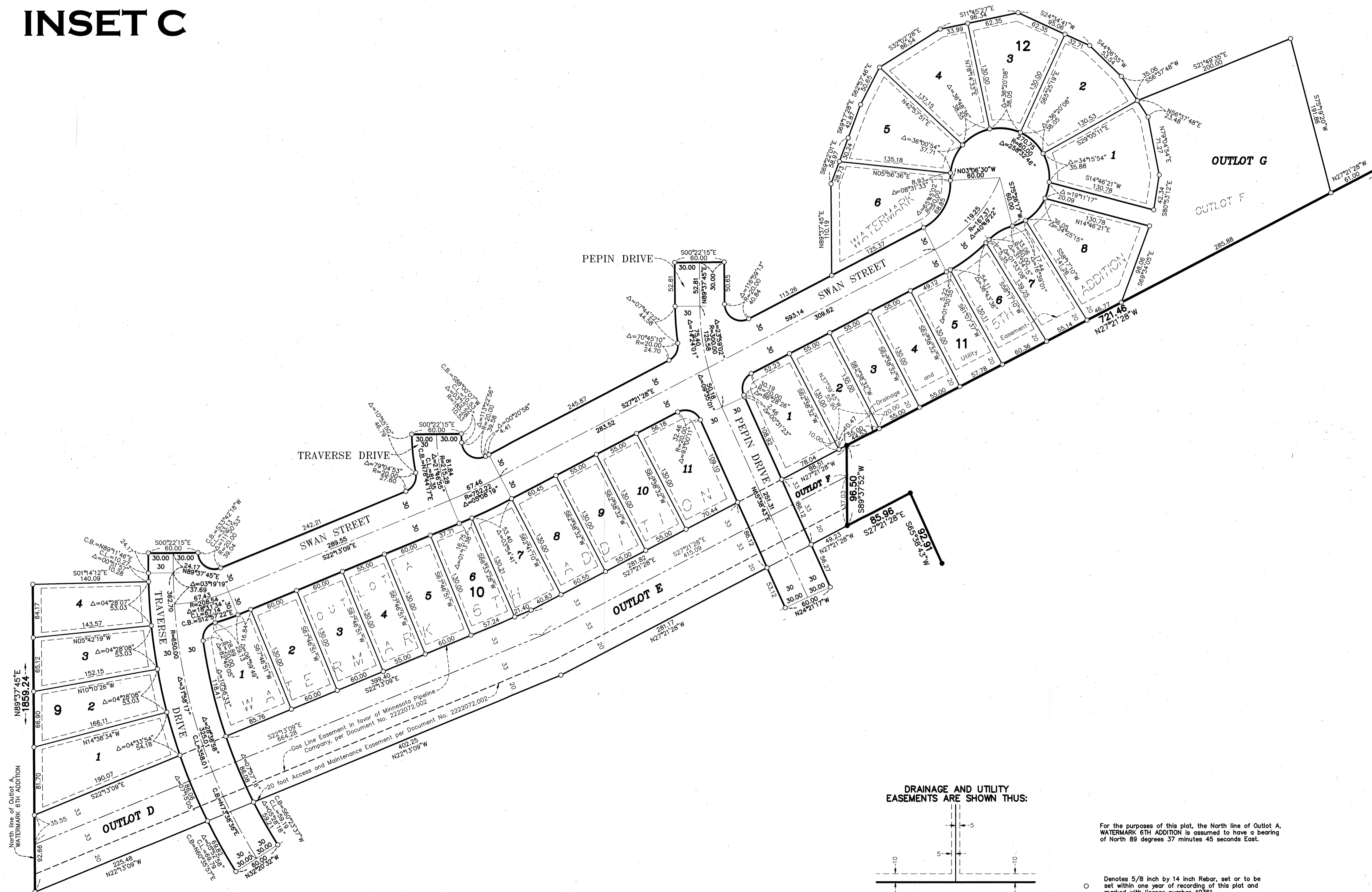

DRAINAGE AND UTILITY
EASEMENTS ARE SHOWN THUS:

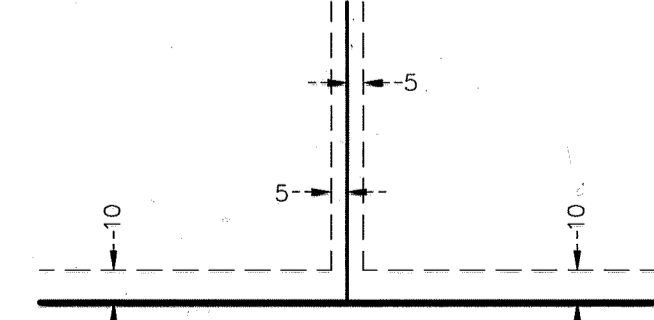

being 5 feet in width, and adjoining side lot lines,
and 10 feet in width and adjoining right of way
lines and rear lot lines unless otherwise shown on
this plat.

For the purposes of this plat, the North line of Outlet A,
WATERMARK 6TH ADDITION is assumed to have a bearing
of North 89 degrees 37 minutes 45 seconds East.

○ Denotes 5/8 inch by 14 inch Rebar, set or to be
set within one year of recording of this plat and
marked with license number 40361

● Denotes Found Iron Monument marked with license number 40361

